

Heavy Duty All-Purpose Chests

- Large capacity, low profile chest mounts to bed of pickup.
- Constructed of heavy-duty diamond tread aluminum (front, ends & lid); smooth aluminum (back & bottom)
- Angled body design is ideal for use with fifth wheel & gooseneck trailer applications. Offset allows full lid access even when flush.
- Top-opening lid features two gas shocks and a one-touch push-button rotary locking mechanism on driver’s side.
- Features removable aluminum sliding storage tray w/ dividers.
- Full rubber automotive grade seal surrounds entire perimeter of lid openings.
- Mounting hardware not included.

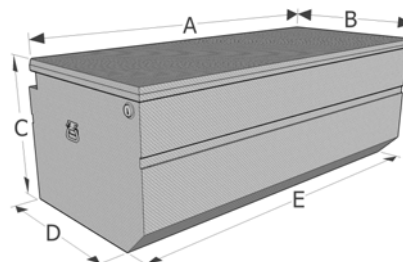

Part #	Description	A	B	C	D	E	UPS	Weight
RB674	Most Trucks (Slanted front)	47"	20"	19"	16"	47"	N	46 lbs
RB654	All Full Size (Slanted front)	54"	20"	19"	16"	54"	N	55 lbs
RB664	All Full Size (Slanted front & ends)	60"	20"	19"	16"	52"	N	60 lbs
RB684	All Full Size L/B Only (No slants)	60"	27"	19"	27"	52"	N	74 lbs

Heavy Duty All-Purpose Jumbo Chests

- Universal storage box that is perfect for the job site.
- Constructed of heavy-duty diamond tread aluminum (front, ends & lid); smooth aluminum (back & bottom)
- Top-opening lid features two gas shocks and a one-touch push-button rotary locking mechanism on driver’s side.
- Features removable aluminum sliding storage tray w/dividers & a large open storage area for your biggest items.
- Full rubber automotive grade seal surrounds entire perimeter of lid openings.

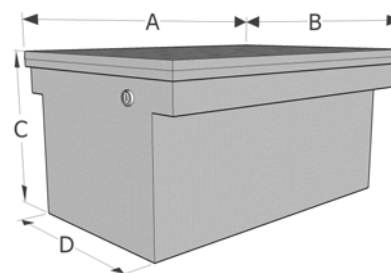

Part #	Description	A	B	C	D	UPS	Weight
RB624	Multi-Purpose	48"	24"	24"	22"	N	76 lbs
RB630	Multi-Purpose	48"	30"	30"	28"	N	95 lbs

Standard Top Front & Rear Offset Chest Boxes

- Chest style box with front & rear offset allows for 85-90° lid opening.
- Constructed of heavy-duty diamond tread aluminum.
- Adjustable stainless steel connecting lockable paddle latch system allows access from either side; rod and latch guards included.
- Includes 2 side chest handles and 2 gas shocks.
- Full rubber automotive grade seal surrounds entire perimeter of lid openings.

Part #	A	B	C	D	E	UPS	Weight
TB400-48	48"	18 ½"	18 ½"	18"	20 ½"	N	40
TB400-55S	55"	20 ½"	20"	19"	22"	N	50
TB400-60	60"	20 ½"	20"	19"	22"	N	55

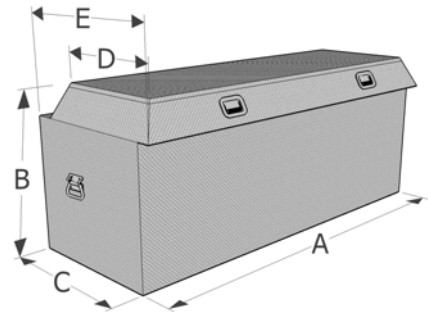

Standard Rear Offset Chest Boxes

- Chest style box with rear offset allows for 85-90° lid opening.
- Constructed of heavy-duty diamond tread aluminum.
- Adjustable stainless steel connecting lockable paddle latch system allows access from either side; rod and latch guards included.
- Includes 2 side chest handles and 2 gas shocks.
- Full rubber automotive grade seal surrounds entire perimeter of lid openings.

Part #	A	B	C	D	UPS	Weight
TB435	35"	15 ½"	16"	14"	Y	27
TB444	44"	18"	20"	18"	Y*	37
TB460	60"	18"	17"	15"	N	44
TB461	60"	18"	20"	18"	N	48

* Ship as FedEx Oversize based on dimensional weight.

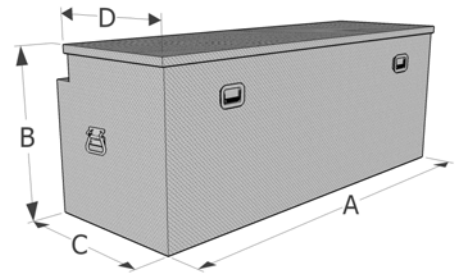

Heavy Duty Pork-Chop Boxes

- Low Profile over-the-wheel mounting offers convenient storage while maximizing pickup truck bed space.
- Constructed of heavy-duty diamond tread aluminum.
- Lid features gas shock and a one-touch push-button rotary locking mechanism.
- Fits most full size pickups.
- Mounting hardware not included.
- May also be mounted in front of wheel wells on full size long beds.
- Full rubber automotive grade seal surrounds entire perimeter of lid openings.

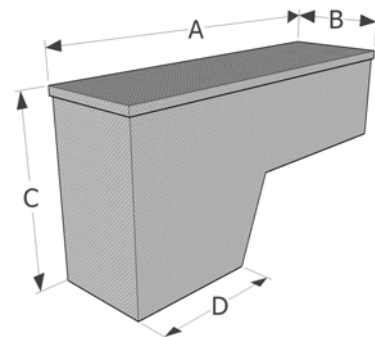

Part #	Description	A	B	C	D	E	UPS	Weight
RB160	Driver side	46 ¼"	9 ¼"	19"	17 ¼"	8 ½"	Y	22 lbs
RB161	Passengers side	46 ¼"	9 ¼"	19"	17 ¼"	8 ½"	Y	22 lbs
RB162	Driver side	46 ¼"	13"	19"	17 ¼"	8 ½"	Y	32 lbs
RB163	Passenger side	46 ¼"	13"	19"	17 ¼"	8 ½"	Y	32 lbs

Sizes and weights are nominal
All products available with black powder coat—Add “-B” to end of part number. (eg. TB400-48-B)